

5/8 λ Mobile Antenna with Shock Spring for the 160 MHz Band

DESCRIPTION

- Sturdy, 3 dB gain, 5/8 λ antenna in professional quality.
- Available with glass fiber or stainless steel whip.
- Stainless steel Z-mount with ball-joint and wing screw whip-fastening system.
- Available with bright or black-chromed metal parts (mount and whip):
 - MH 3-Z...: Bright version
 - MH 3-BZ...: Black version
- Simple mounting exclusively with access from the outside.
Models with roof thickness from 2 mm to 7.5 mm mounting from the inside.
- Choice between two connection principles:
 - Z-mount: FME-connection (supplied without cable).
 - ZP4-mount: Permanently attached 4 m cable terminated with FME-connector.



SPECIFICATIONS

Electrical	
Model	MH 3-Z
Frequency	Tunable by cutting within : 144-175 MHz
Antenna Type	Mobile whip antenna
Max. Input Power	150 W
Polarisation	Vertical
Impedance	50 Ω
VSWR	≤ 1.3:1 @ f.res.
Bandwidth	4 - 5 MHz @ VSWR ≤ 2.0
Gain (EIA RS-329-1)	3 dB
Mechanical	
Materials	Whip : Conical glass fiber or stainless steel Chromed brass Spring : Stainless steel Mount : Chromed brass Weather- and shockproof plastics Stainless steel
Installation Torque	7.5 ±1 Nm
Colour	Bright or black, see above
Height	Approx. 1380 mm / 54.33 in.
Weight	Z-version : Approx. 360 g / 0.80 lb. ZP4-version : Approx. 510 g / 1.12 lb.
Mounting	21 mm dia. hole (For roof thicknesses 2 mm up to 7.5 mm mounting hole should be 22mm dia.)
Mounting Plate Thickness	Max. 2.0 mm (Models up to 7.5 mm on request)

ORDERING

Model	Product No.	Description	Frequency
MH 3-Z	130000743	Glassfibre Whip	Z-mount with FME-system BRIGHT
MH 3-ZR	130000751	Stainless Steel Whip	Z-mount with FME-system BRIGHT
MH 3-BZP4	130000746	Glassfibre Whip	BZP4-mount with 4 m cable + FME-connector BLACK
MH 3-BZP4R	130000752	Stainless Steel Whip	BZP4-mount with 4 m cable + FME-connector BLACK
MH 3-ZP4	130000745	Glassfibre Whip	ZP4-mount with 4 m cable + FME-connector BRIGHT
MH 3-ZP4R	130000753	Stainless Steel Whip	ZP4-mount with 4 m cable + FME-connector BRIGHT
MH 3-BZ	130000747	Glassfibre Whip	BZ-mount with FME-system BLACK
MH 3-BZR	130000758	Stainless Steel Whip	BZ-mount with FME-system BLACK

THE WHIP IS COMPATIBLE WITH ALL BELOW MOUNTS

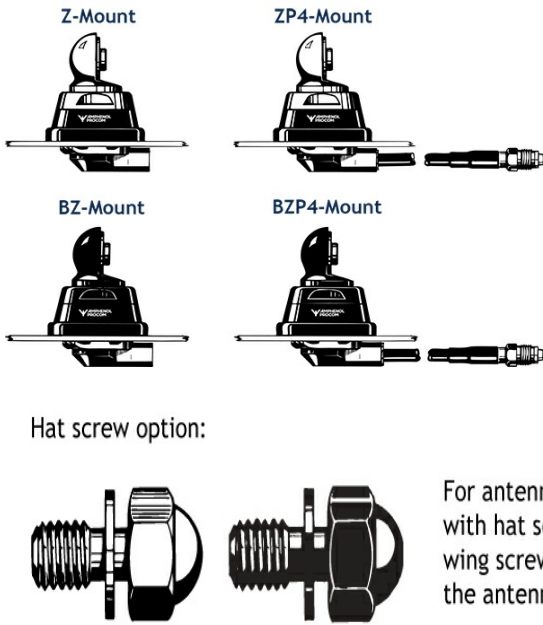

2. INSTALLATION STEPS

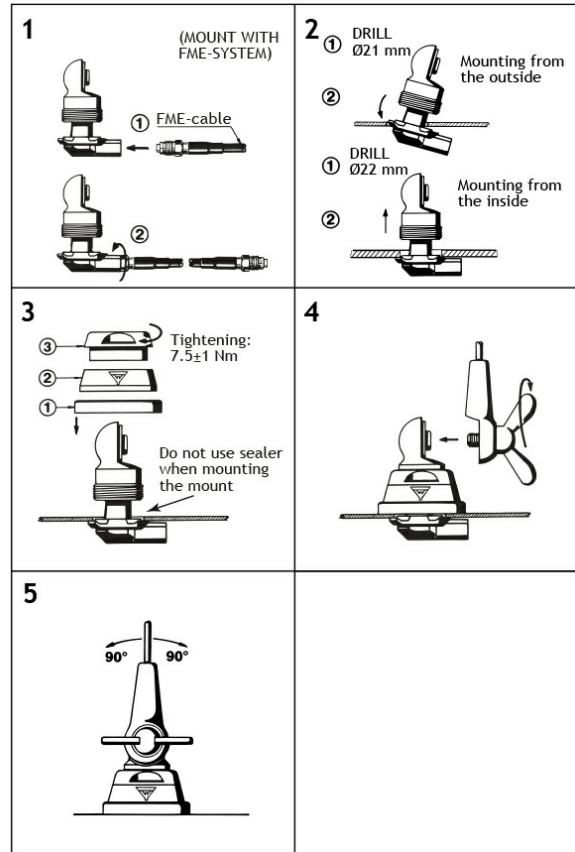

INSTALLATION

This antenna is provided with type Z-mount. The whip is fastened to the mount by means of our standard ball-joint and wing screw system. The adjustable ball-joint ensures that the whip can always be mounted in a vertical position independent of the angle of the installation spot.

The Z-mount is particularly well suited for mounting on car-roofs because of its ability to be installed exclusively with access from the outside. The Z-Mount for roof thickness from 2 mm to 7.5 mm must be mounted from the inside.

However, the antenna can be installed anywhere on the car, as the Z-mount is equally well suited for mounting on e.g. trunk or wing.

Do not use sealer on rubber gasket or other places.

1. INSTALLATION DIMENSION

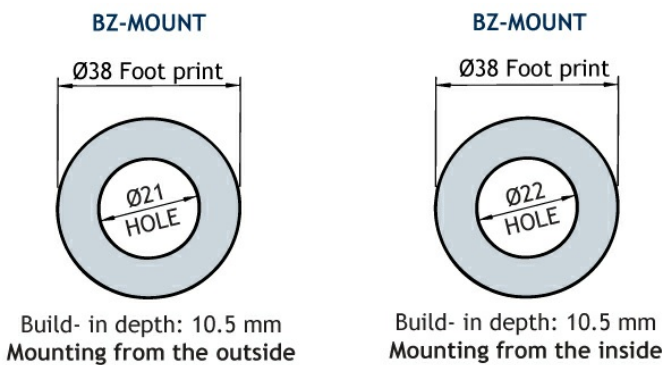

3. TUNING

The antenna should always be tuned using an VSWR-meter. The cutting diagrams below serve as a guide for this procedure.

